

# question sheet

company:	phone:
contact:	fax:
street:	email:
postal code, city:	date:

## information

- position spindle horizontal
- position spindle vertical
- chain magazine
- disc magazine
- number of positions \_\_\_\_\_
- tools are taken directly from the corresponding spindle from the magazine (pick-up)
- tools are removed with a tool changer from the magazine

## specification of the tools

- tool support [1] \_\_\_\_\_
- tool weight max. \_\_\_\_\_ kg
- tool length max. [ $L_{max}$ ] \_\_\_\_\_ mm
- outer diameter max. [ $D_{max}$ ]
  - if adjacent location occupied: \_\_\_\_\_ mm
  - with free adjacent pockets: \_\_\_\_\_ mm

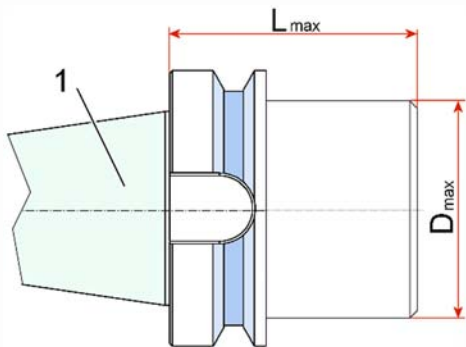

## other

---



---



---



---

M0902DE/1202